

## ATTENZIONE - ATTENTION - ACHTUNG

- VERIFICARE LE MISURE DI INGOMBRO PER POSSIBILE INTERFERENZA SU ALCUNI MODELLI DI MACCHINE
- Please check the overall sizes for possible interferences on some machine models
- Bitte überprüfen sie das ausmass um mögliche interferenzen auf einigen maschinen modellen zu vermeiden

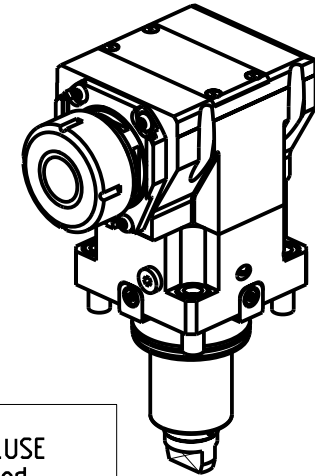
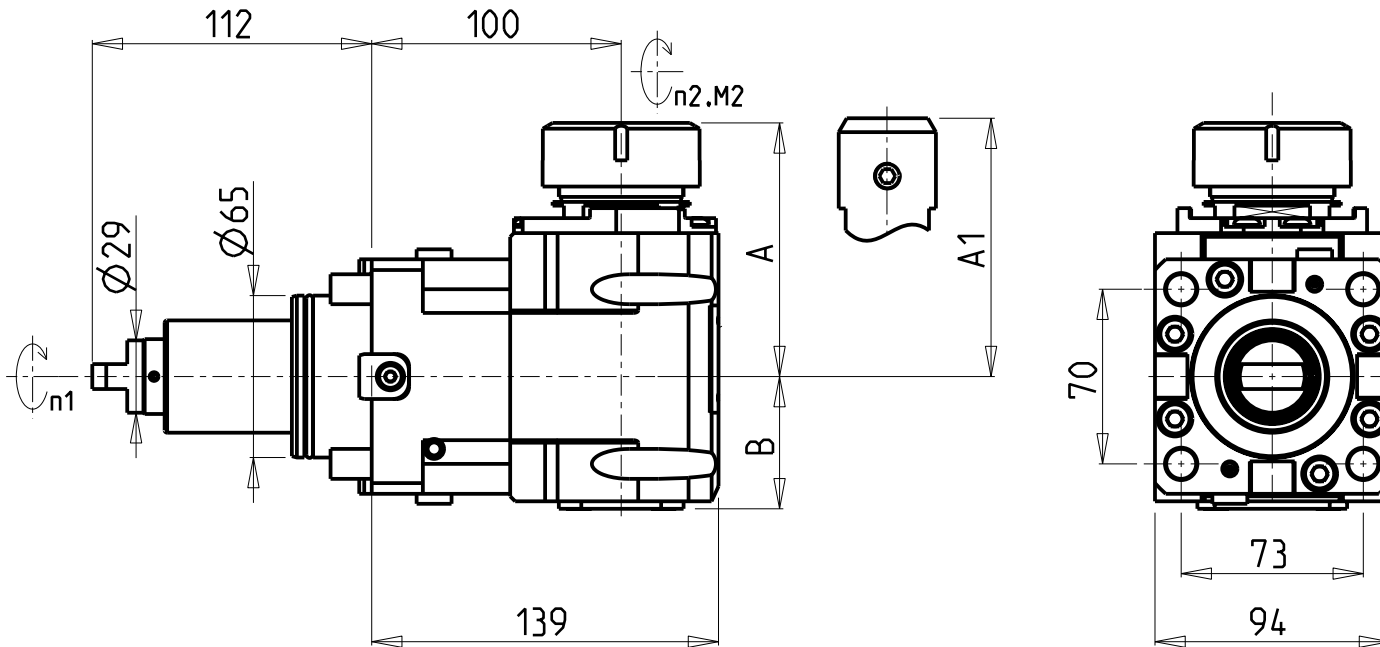

- Chiave inclusa
- Key included
- Schlüssel inbegriffen

Cod. MT	Mandrino Spindle Spindel	I (n1:n2)	RPM max n2	Coppia Max Max Torque Max Drehmoment M2 (Nm)	Reversibile 180° 180° Reversible 180° umsetzbar	Lubrificazione int. Coolant through Innenkuehlung Pmax (bar)	Lubr.esterna Ext. coolant Aussenkuehlung	Lav. secco Dry-run Trocken Bearb.	A	A1	B	CHIAVI NON INCLUSE Keys not included Schlüssel nicht einbegriffen	
DW 02360132	ER32	2:1	3000	130	X	-	X	X	98.7	-	53	OKU0650004	CHSTER32
DW 02360232	ER32	2:1	3000	130	X	70	X	-	98.7	-	66.5	OKU0650004	CHSTER32
DW 02360140	ER40	2:1	3000	130	X	-	X	X	101.7	-	53	OKU0650004	CHSTER40
DW 02360240	ER40	2:1	3000	130	X	70	X	-	101.7	-	66.5	OKU0650004	CHSTER40
DW 02360725	WELDON 25	2:1	3000	130	X	-	X	X	-	106	53	-	-
DW 02360825	WELDON 25	2:1	3000	130	X	70	X	-	-	106	66.5	-	-

### DN SOLUTIONS (DOOSAN) BMT 65

MOD: PUMA 300M/MS - V400M - TT2000SY-TT2500SY-TT2500MS - PUMA 2100-2600M/MS/Y/SY (BMT65) - PUMA 3100 M/Y  
MX2000ST - MX2500LT/ST/LST - MX2600T-ST - VT 450M/TM - PUMA INVERTURN 3000M - PUMA GT3100 M - SMX2600/3100ST

MODULO MOTORIZZATO ASSIALE RIDOTTO I=2:1 H=100mm  
Axial geared-down I=2:1 driven tool H=100mm  
Axial angetriebenes Werkzeug untersetzt I=2:1 H=100mm

Subject to change without notice.

### M.T. srl

Via Casino Albini 480  
Tel. 0541/956034-957884  
Fax 0541/956341  
47842 S. GIOVANNI IN M. (RN)  
e-mail: mtma@mtmarchetti.com  
http://www.mtmarchetti.com



DW 0190-3-30