

Ø16
TOOL DIAMETER

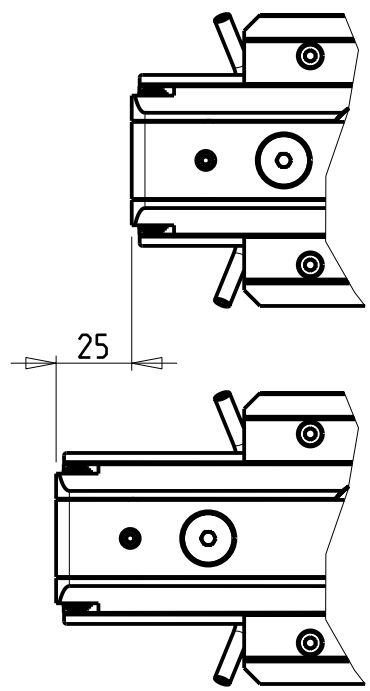
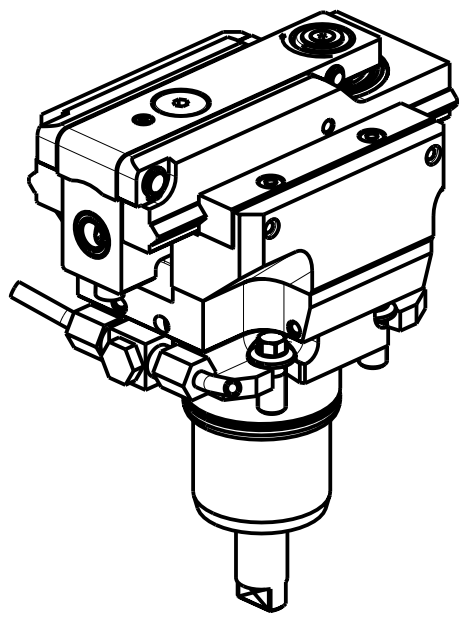

DOTAZIONI - SUPPLIED WITH - AUSSTATTUNG

- N°1 Boccola di riduz. Ø16-Ø12 e N°1 Boccola di riduz. Ø16-Ø10
- N°1 Reduction bush Ø16-Ø12 and N°1 Reduction bush Ø16-Ø10
- N°1 Reduzierbuchsen Ø16-Ø12 und N°1 Reduzierbuchsen Ø16-Ø10

PER UTENSILI STOZZATORI VEDI PAG. TBL400-1-00
 FOR DRIVEN SLOTTING TOOL CUTTING-TOOLS SEE PAGE TBL400-1-00
 FÜR NUTENSTOSS-WERKZEUG SCHNEIDWERKZEUGE SIEHE SEITE TBL400-1-00

Cod. MT	I	RPM max n1	Reversibile lato mandrino/contromandrino Reversible sub/main spindle side Umkehrbare Spindel-seite/ Gegenspindel-seite	Lubr. esterna Ext. coolant Aussenkuehlung	Lav. secco Dry-run Trocken Bearb.
NKM0910200	4:1	2400	X	X	-

CMZ
 MOD: TX52 Y3/Y2 QUATTRO/Y2 TW IN - TX66 Y3/Y2 QUATTRO/Y2 TW IN - TTL 52 - TTL 66
 TA15-20-25-30M/Y/MS/MY/YS 15 ST.

MODULO MOTORIZZATO STOZZATORE CORSA 25mm H=66mm
 Slotting driven tool 25mm stroke H=66mm
 Keilnutenstossmaschine 25mm Hub H=66mm

M.T. srl
 Via Casino Albini 480
 Tel. 0541/956034-957884
 Fax 0541/956341
 47842 S. GIOVANNI IN M. (RN)
 e-mail: mtma@mtmarchetti.com
 http://www.mtmarchetti.com



CMZ360-3-01

Subject to change without notice.