

ATTENZIONE - ATTENTION - ACHTUNG

- Per lo smontaggio degli utensili utilizzare sempre la chiave di contrasto come indicato nel manuale d'uso.
- For disassembly of the tools use always the contrast key as mentioned in the user instructions.
- Fuer das Abmontieren der Werkzeuge immer den Gegenschlüssel benutzen wie in der Bedienungsanleitung erwaehnt.

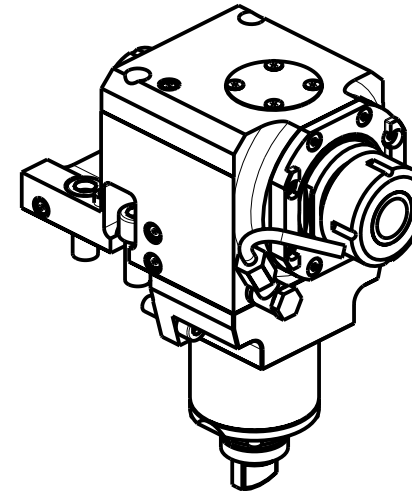
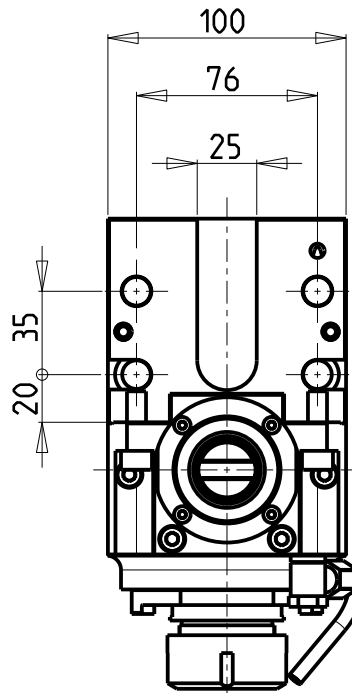
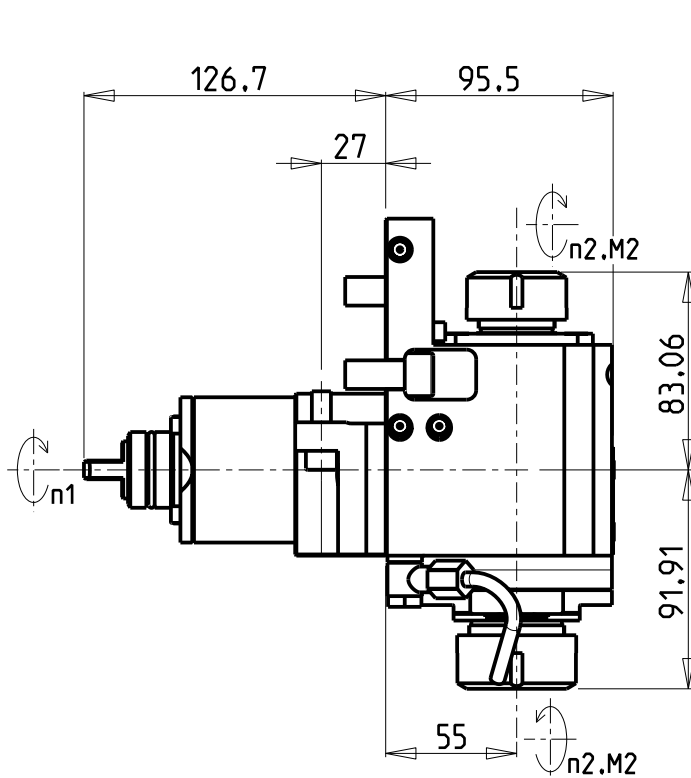

Cod. MT	Mandrino Spindle Spindel	I (n1:n2)	RPM max n2	Coppia Max Max Torque Max Drehmoment M2 (Nm)	Lubrificazione est. Ext. coolant Aussenkuehlung	Lav. secco Dry-run Trocken Bearb.	CHIAVI NON INCLUDE Keys not included Schlüssel nicht einbegriffen		
MSL0173225	ER32+ER25	1:1	6000	105	X	X	MNZ0410005 *	CHSTER32	CHSTER25

- Chiave inclusa
- Key included
- Schlüssel inbegriffen

CMZ

MOD:TL25AM/AMS/BM/BMS - TL20M/MS/TM - TA15-20-25-30M/Y/MS/MY/YS 12ST. - TC15-20-25-30-35M/Y/MS/MY/YS 12ST./16ST.
TD15-20-25-30-35-45-55M/Y/MS/MY/YS 12ST./16ST.

MODULO MOTORIZZATO ASSIALE BISPORGENTE
Axial opposite face twin driven tool
Axial angetriebenes Werkzeug halb vorspringend

Subject to change without notice.

M.T. srl

Via Casino Albini 480
Tel. 0541/956034-957884
Fax 0541/956341
47842 S. GIOVANNI IN M. (RN)
e-mail: mtma@mtmarchetti.com
http://www.mtmarchetti.com



CMZ240-2-10