

ATTENZIONE - ATTENTION - ACHTUNG

- VERIFICARE LE MISURE DI INGOMBRO PER POSSIBILE INTERFERENZA SU ALCUNI MODELLI DI MACCHINE
- Please check the overall sizes for possible interferences on some machine models
- Bitte überprüfen sie das ausmass um mögliche interferenzen auf einigen maschinen modellen zu vermeiden

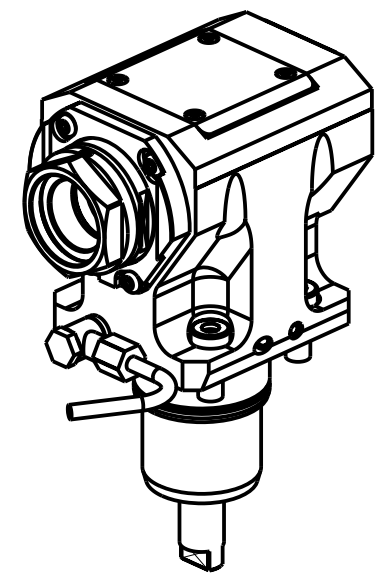

PER PORTAUTENSILI MODULARI MTSK-40 VEDI PAG. TBL300-1-40
 FOR MTSK-40 QUICK CHANGE TOOLHOLDERS CLAMPINGS SEE PAGE TBL300-1-40
 FUER MTSK-40 MODULARE WERKZEUGAUFNAHMEN SIEHE SEITE TBL300-1-40

Cod. MT	Mandrino Spindle Spindel	I (n1:n2)	RPM max n2	Coppia Max Max Torque Max Drehmoment M2 (Nm)	Reversibile 180° 180° Reversible 180° umsetzbar	Lubrificazione int. Coolant through Innenkuehlung Pmax (bar)	Lubrificazione est. Ext. coolant Aussenkuehlung	Lav. secco Dry-run Trocken Bearb.	B	CHIAVI NON INCLUSE Keys not included Schluessel nicht einbegriffen	
NKM1410140	MTSK-40	1:1	6000	50	X	-	X	X	56.5	CHUB46	OKU0650004 ■
NKM1410240	MTSK-40	1:1	6000	50	X	100 (diag. 2)	X	X	67.5	CHUB46	OKU0650004 ■

- Chiave inclusa
- Key included
- Schluessel inbegriffen

CMZ
 MOD: TX52 Y3/Y2 QUATTRO/Y2 TWIN - TX66 Y3/Y2 QUATTRO/Y2 TWIN - TTL 52 - TTL 66
 TA15-20-25-30M/Y/MS/MY/YS 15 ST.

MODULO MOTORIZZATO ASSIALE MTSK H=75mm
 Axial MTSK driven tool H=75mm
 Axial MTSK angetriebenes Werkzeug H=75mm

M.T. srl
 Via Casino Albini 480
 Tel. 0541/956034-957884
 Fax 0541/956341
 47842 S. GIOVANNI IN M. (RN)
 e-mail: mtma@mtmarchetti.com
 http://www.mtmarchetti.com



CMZ150-3-21-K

Subject to change without notice.