

### ATTENZIONE - ATTENTION - ACHTUNG

-Su macchine B545/B565/B650 non utilizzare su lato contromandrino.

-On B545/B565/B650 do not use on sub-spindle side.

-Auf B545/B565/B650 Maschinen nicht auf der gegenspindel-seite benutzen.

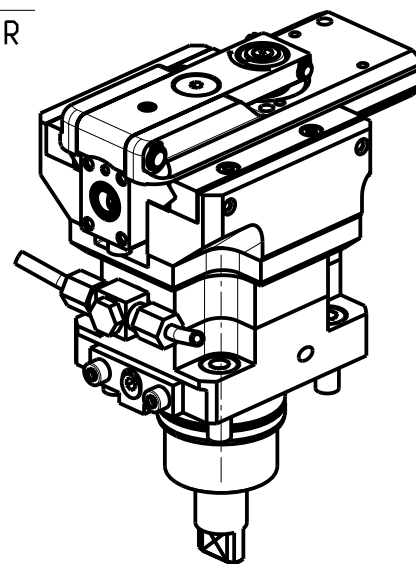
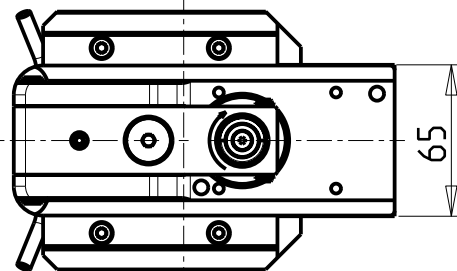
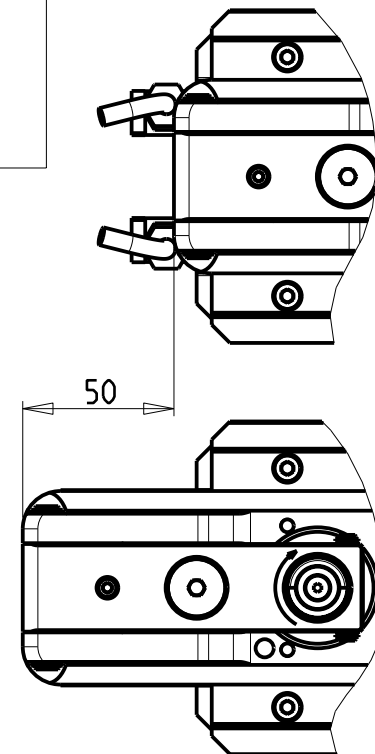

### DOTAZIONI - SUPPLIED WITH - AUSSTATTUNG

N\*1 Boccola di riduz.  $\varnothing 16-\varnothing 12$  e N\*1 Boccola di riduz.  $\varnothing 16-\varnothing 10$   
 N\*1 Reduction bush  $\varnothing 16-\varnothing 12$  and N\*1 Reduction bush  $\varnothing 16-\varnothing 10$   
 N\*1 Reduzierbuchsen  $\varnothing 16-\varnothing 12$  und N\*1 Reduzierbuchsen  $\varnothing 16-\varnothing 10$

PER UTENSILI STOZZATORI VEDI PAG. TBL400-1-00  
 FOR DRIVEN SLOTTING TOOL CUTTING-TOOLS SEE PAGE TBL400-1-00  
 FÜR NUTENSTOSS-WERKZEUG SCHNEIDWERKZEUGE SIEHE SEITE TBL400-1-00

Cod. MT	I	RPM max n1	Reversibile 180° 180° Reversible 180° umsetzbar	Lubr. esterna Ext. coolant Aussenkuehlung	Lav. secco Dry-run Trocken Bearb.
BGL0330100	4:1	2000	X	X	-

**BIGLIA**  
 MOD: B445/470/545/550/565/650/658/1200/446/465/745/765 - B750/1250 16 ST.

MODULO MOTORIZZATO STOZZATORE CORSA 50mm H=100mm  
 Slotting driven tool 50mm stroke H=100mm  
 Keilnutenstossmaschine 50mm Hub H=100mm

Subject to change without notice.

**M.T. srl**

Via Casino Albini 480  
 Tel. 0541/956034-957884  
 Fax 0541/956341  
 47842 S. GIOVANNI IN M. (RN)  
 e-mail: mtma@mtmarchetti.com  
 http://www.mtmarchetti.com



BGL360-1-10