

Ø16
TOOL DIAMETER

ATTENZIONE - ATTENTION - ACHTUNG

-Su macchine B545/B565/B650 non utilizzare su lato contromandrino.

-On B545/B565/B650 do not use on sub-spindle side.

-Auf B545/B565/B650 Maschinen nicht auf der gegenspindel-seite benutzen.

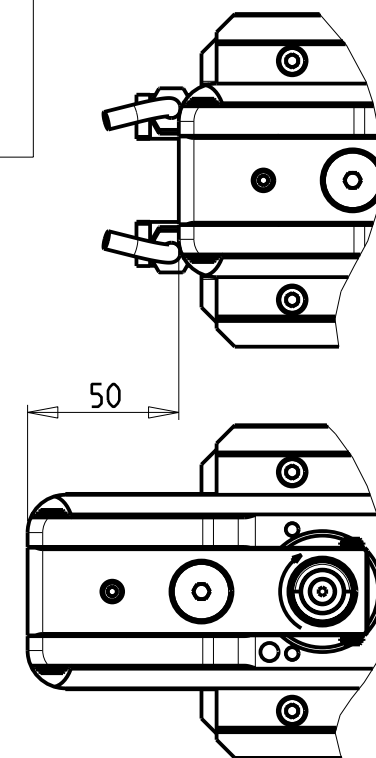
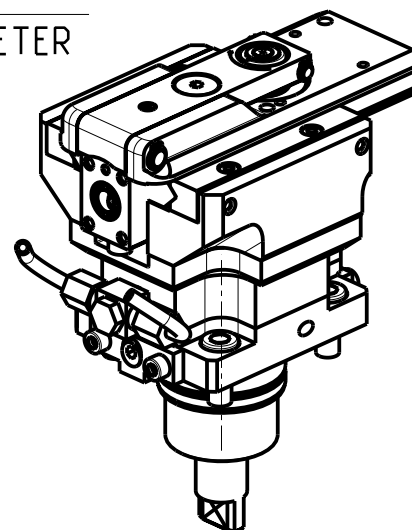

DOTAZIONI - SUPPLIED WITH - AUSSTATTUNG

N*1 Boccola di riduz. Ø16-Ø12 e N*1 Boccola di riduz. Ø16-Ø10
 N*1 Reduction bush Ø16-Ø12 and N*1 Reduction bush Ø16-Ø10
 N*1 Reduzierbuchsen Ø16-Ø12 und N*1 Reduzierbuchsen Ø16-Ø10

PER UTENSILI STOZZATORI VEDI PAG. TBL400-1-00
 FOR DRIVEN SLOTTING TOOL CUTTING-TOOLS SEE PAGE TBL400-1-00
 FÜR NUTENSTOSS-WERKZEUG SCHNEIDWERKZEUGE SIEHE SEITE TBL400-1-00

Cod. MT	I	RPM max n1	Reversibile 180° 180° Reversible 180° umsetzbar	Lubr. esterna Ext. coolant Aussenkuehlung	Lav. secco Dry-run Troekken Bearb.
BGL0320100	4:1	2000	X	X	-

BIGLIA

MOD: B301/445/470/501(Y-S)/510/545/550/565/620/650/658/1200 - BMX 51/70Y2 15ST.

MODULO MOTORIZZATO STOZZATORE CORSA 50mm H=85mm

Slotting driven tool 50mm stroke H=85mm

Keilnutenstossmaschine 50mm Hub H=85mm

Subject to change without notice.

M.T. srl

Via Casino Albini 480
 Tel. 0541/956034-957884
 Fax 0541/956341
 47842 S. GIOVANNI IN M. (RN)
 e-mail: mtma@mtmarchetti.com
 http://www.mtmarchetti.com



BGL360-1-00