

ATTENZIONE - ATTENTION - ACHTUNG

- Con l'utensile orientato a 0° o 180°, non è possibile eseguire lavorazioni a centro-pezzo!
- It is not possible to make machining operations at the center of the part with tool oriented at 0° or at 180°
- Mit einem Werkzeug um 0° oder 180° orientiert, ist es nicht möglich, Verarbeitung von der Werkzeug-Mitte auszuführen.

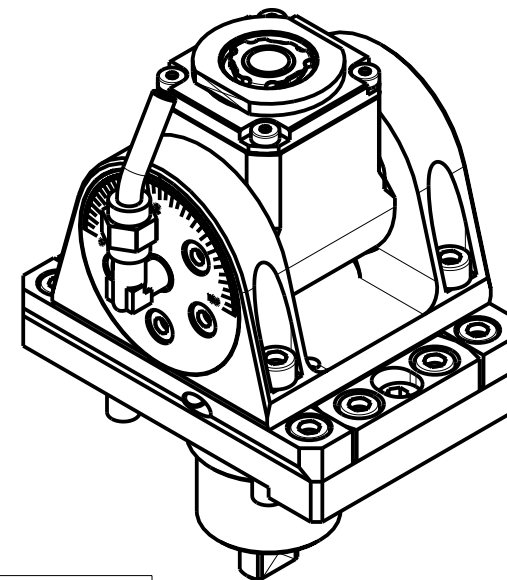

Cod. MT	Mandrino Spindle Spindel	I (n1:n2)	RPM max n2	Coppia Max Max Torque Max Drehmoment	Reversibile 180° 180° Reversible 180° umsetzbar	Lubrificazione int. Coolant through Innenkuehlung	Lubr.esterna Ext. coolant Aussenkuehlung	Lav. secco Dry-run Trocken Bearb.	CHIAVI INCLUSE Keys included Schluessel inbegriffen			
				M2 (Nm)		Pmax (bar)						
BGL1100120	ER A 16	1:1	6000	20	X	-	X	X	CHUB19_SP3	CHUB32	CHESL05	CHTAER16ZC
BGL1100220	ER A 16	1:1	6000	20	X	70	X	-	CHUB19_SP3	CHUB32	CHESL05	CHTAER16ZC

BIGLIA

MOD: B436/438 - BMX 45Y2

MODULO MOTORIZZATO ORIENTABILE ±90° H=48mm

±90° adjustable angle driven tool H=48mm

Angetriebenes Werkzeug schwenkbar ±90° H=48mm

Subject to change without notice.

M.T. srl

Via Casino Albini 480
Tel. 0541/956034-957884
Fax 0541/956341

47842 S. GIOVANNI IN M. (RN)
e-mail: mtma@mtmarchetti.com
http://www.mtmarchetti.com



BGL335-2-00