

ATTENZIONE - ATTENTION - ACHTUNG

- Per lo smontaggio degli utensili utilizzare sempre la chiave di contrasto come indicato nel manuale d'uso.
- For disassembly of the tools use always the contrast key as mentioned in the user instructions.
- Fuer das Abmontieren der Werkzeuge immer den Gegenschlüssel benutzen wie in der Bedienungsanleitung erwäohnt.

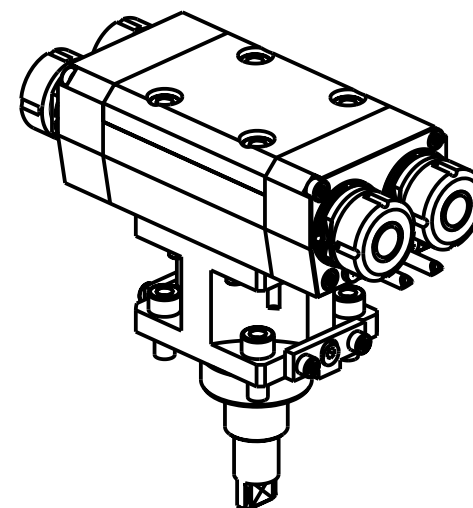

Cod. MT	Mandrino Spindle Spindel	I (n1:n2)	RPM max n2	Coppia Max Max Torque Max Drehmoment	Reversibile 180° 180° Reversible 180° umsetzbar	N°Utensili N°Tools N°Werkzeuge	Lubr.esterna Ext. coolant Aussenkuehlung	Lav. secco Dry-run Trocken Bearb.	A	B	CHIAVI NON INCLUDE Keys not included Schlüssel nicht einbegriffen	
				M2 [Nm]							CHUB17	CHMNER16
BGL0571416	ER16+ER16	1:1	6000	50	X	2+2	X	X	114.7	120.7	CHUB17	CHMNER16
BGL0571425	ER25+ER25	1:1	6000	50	X	2+2	X	X	115.6	121.6	CHUB36	CHSTER25

BIGLIA

MOD: B445/470/446/465/745/765 - B750/1250 16 ST.

MODULO MOTORIZZATO ASSIALE 2+2 USCITE IN Y H=100mm

Axial multiple 2+2 outlet driven tool in Y H=100mm

Axial angetriebenes Mehrspindel-Werkzeug 2+2 Ausgaenge in Y H=100mm

Subject to change without notice.

M.T. srl

Via Casino Albini 480
Tel. 0541/956034-957884
Fax 0541/956341
47842 S. GIOVANNI IN M. (RN)
e-mail: mtma@mtmarchetti.com
http://www.mtmarchetti.com



BGL268-1-20