

ATTENZIONE - ATTENTION - ACHTUNG

- Per lo smontaggio degli utensili utilizzare sempre la chiave di contrasto come indicato nel manuale d'uso.
- For disassembly of the tools use always the contrast key as mentioned in the user instructions.
- Fuer das Abmontieren der Werkzeuge immer den Gegenschlüssel benutzen wie in der Bedienungsanleitung erwähnt.

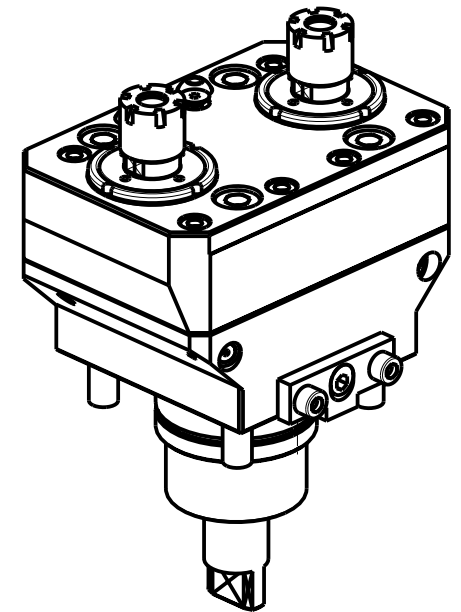

Cod. MT	Mandrino Spindle Spindel	I (n1:n2)	RPM max n2	Coppia Max Max Torque Max Drehmoment M2 (Nm)	Reversibile 180° 180° Reversible 180° umsetzbar	Lubr.esterna Ext. coolant Aussenkuehlung	Lav. secco Dry-run Trocken Bearb.	CHIAVI NON INCLUDE Keys not included Schluessel nicht einbegriffen	
BGL0030216	ER16	1:2	12000	20	X	X	X	CHMNER16	CHUB17

BIGLIA

MOD: B301/445/470/501(Y-S)/510/545/550/565/620/650/658/1200/446/465/745/765 - B750/1250 16 ST. - BMX 51/70Y2 15ST. - BV210/315

MODULO MOTORIZZATO RADIALE 2 USCITE IN Y MOLTIPLICATO I=1:2
 Radial geared-up I=1:2 single side twin head driven tool in Y
 Radial angetriebenes Werkzeug 2 Ausgaenge in Y uebersetzt I=1:2

Subject to change without notice.

M.T. srl
 Via Casino Albini 480
 Tel. 0541/956034-957884
 Fax 0541/956341
 47842 S. GIOVANNI IN M. (RN)
 e-mail: mtma@mtmarchetti.com
 http://www.mtmarchetti.com



BGL080-1-10