

ATTENZIONE - ATTENTION - ACHTUNG

- FINO AD ESAURIMENTO SCORTE
- clearance sale
- solange vorrat

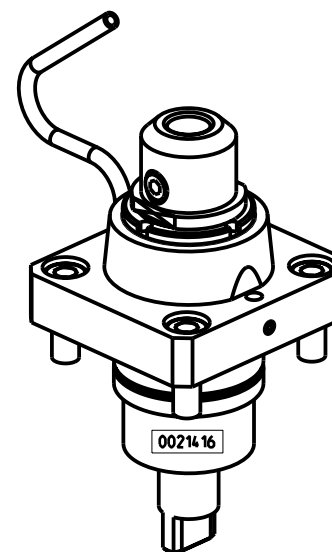
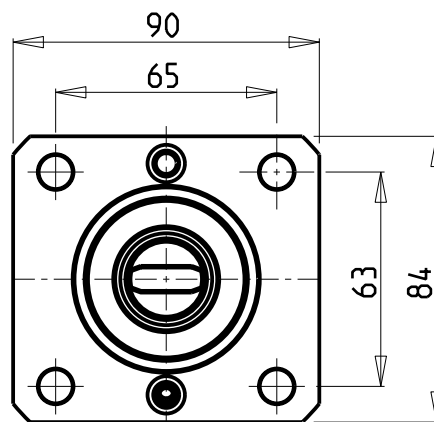
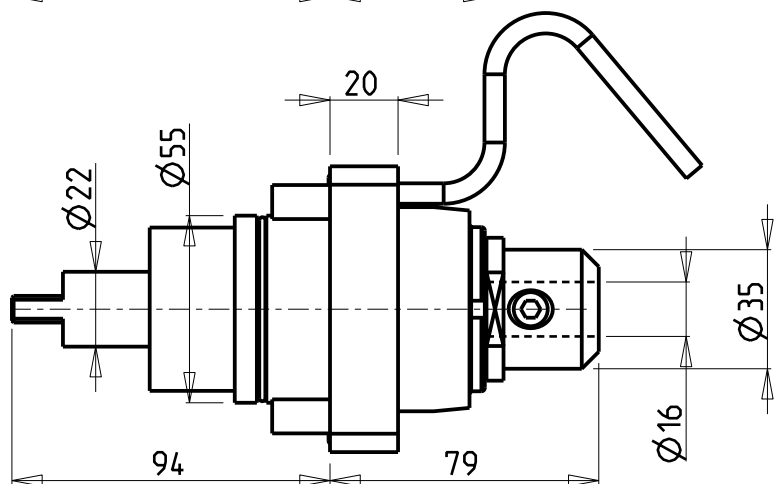

Cod. MT	Cod. BIGLIA	Mandrino Spindle Spindel	I	RPM	Coppia Max Max Torque Max Drehmoment	Lubrificazione est. Ext. coolant Aussenkuehlung	CHIAVI NON INCLUSE Keys not included Schluessel nicht einbegriffen	
0021225	T134-00049	ER25 CORTO SHORT KURZ	1:1	6000	50Nm	X	CHSTER25	0100000_1
0021416	-	WELDON 16	1:1	6000	50Nm	X	-	-

BIGLIA

MOD: B301/445/470/501(Y-S)/510/545/550/565/620/650/658/1200/446/465/745/765
B750/1250 16 ST. - BV210/315

MODULO MOTORIZZATO RADIALE

Radial driven tool

Radial angetriebenes Werkzeug

Subject to change without notice.

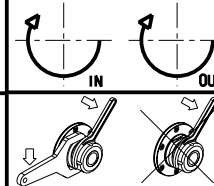

M.T. srl

Via Casino Albini 480
Tel. 0541/956034-957884
Fax 0541/956341
47842 S. GIOVANNI IN M. (RN)
e-mail: mtma@mtmarchetti.com
http://www.mtmarchetti.com

PRODUZIONE MODULI ROTANTI



PAGINA BGL010-1-00