

ATTENZIONE - ATTENTION - ACHTUNG

- VERIFICARE LE MISURE DI INGOMBRO PER POSSIBILE INTERFERENZA SU ALCUNI MODELLI DI MACCHINE
- Please check the overall sizes for possible interferences on some machine models
- Bitte überprüfen sie das ausmass um mögliche interferenzen auf einigen maschinen modellen zu vermeiden

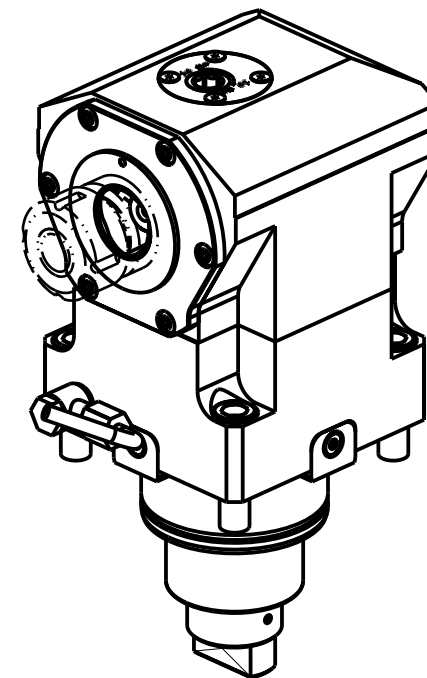

Cod. MT	TAGLIA Size Masse	I	RPM	Coppia Max Max Torque Max Drehmoment	Reversibile lato mandrino/contromandrino Reversible sub/main spindle side Umkehrbare Spindel-seite/ Gegenspindel-seite	Lubr.interna Coolant through Innenkuehlung	Lubr.esterna Ext. coolant Aussenkuehlung	L2
DW 034 30140	C4	1:1	6000	140Nm	X	-	X	63
DW 034 30240	C4	1:1	6000	140Nm	X	P=70bar	X	75.5
DW 034 30150	C5	1:1	6000	140Nm	X	-	X	63
DW 034 30250	C5	1:1	6000	140Nm	X	P=70bar	X	75.5

SMART

MOD: NL4000/5000 M/LM/LY

MODULO MOTORIZZATO ASSIALE MT CAPTO H=110mm

Axial driven tool MT CAPTO H=110mm

Axial angetriebenes Werkzeug MT CAPTO H=110mm

Subject to change without notice.

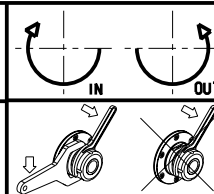

M.T. srl

Via Casino Albini 480
Tel. 0541/956034-957884

Fax 0541/956341

47842 S. GIOVANNI IN M. (RN)

e-mail: mtma@mtmarchetti.com

http://www.mtmarchetti.com



SMA150-C-44